



# ONVIF 4 Megapixel Vandal Dome

IP Camera



**NEW** 2015 SEP. V1.0



## IP Surveillance

# VIG-DME55

# VIG-DME55V

- 4 Mega Pixel 1/3" CMOS Image Sensor.
- Real-time H.264,H.265+, MJPEG Compression(Dual Codec).
- Resolution : 2688x1520.
- Simultaneous Multiple Streams.
- 24 IR LEDs, IR Range 15M.
- Supports ONVIF Standard to Simplify Integrationand Enhance Interoperability.

# VIG-DME55 4 Megapixel Vandal Dome VIG-DME55V IP Camera



Dimension Unit: mm

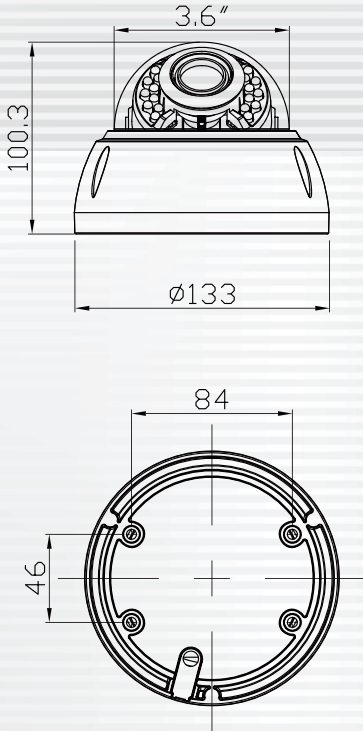

## SPECIFICATIONS

Model		VIG-DME55	VIG-DME55V
System	Flash	Flash : 16MB	
	RAM	RAM : 256MB	
Image Sensor	4 Megapixel High Quality 1/3" CMOS Image Sensor		
Sensitivity	0 Lux (IR ON)		
IR LEDs	24 pcs		
IR Range	15 M		
Lens	Megapixel CS mount	Varifocal 2.8-12mm F1.4	
	Removable IR-cut filter for day & night function		
Video	H.264/H.265+ : 2688x1520 at 12fps		
	H.264/H.265+ : 1920x1080 at 25 fps		
	H.264/H.265+ : 1600x1200 at 25 fps		
	H.264/H.265+ : 1280x720 at 30 fps		
	H.264/H.265+ : 640x480 at 30 fps		
Compression: H.264,H.265+, MJPEG Streaming: Dual Codec (H.264 · H.265+ · JPEG) Selectable			
Support Simultaneous multiple streams			
Image Settings	Adjustable image size, quality, and bit rate		
	Time/Date stamp and text caption overlay.		
	BNC connector for video output, NTSC/PAL video output switch		
	Adjustable image size, quality, and bit rate		
	Time/Date stamp and text caption overlay.		
Configurable brightness, contrast, saturation, sharpness, white balance and exposure			
AGC / AWB / AES			
Networking	Interface	10/100 Mbps Ethernet, RJ-45	
	Supported Protocol	IPv4,TCP/IP,DHCP,HTTP,RTSP,SNTP,DNS	
	Supported Browser	Microsoft Internet Explorer 6.0 or above	
Alarm and Event Management	Motion Detection		
	Event notification using SMTP or FTP		
Users	8 clients on-line monitoring at the same time		
	Multi-level user access control with password protection		
Maintenance	Supports online firmware upgrade		
I/O	RJ-45 Ethernet x 1,DC Jack x1		
Power	DC12V or PoE IEEE802.3af Class 0 (optional)		
Max. Power Consumption	3.6W(IR OFF),7W(IR ON)		
Weight	Netweight: 1050 g		
Dimension	W:Φ135mm H:110mm		
Operating Environments	Temperature: 0 ~ 45 °C Humidity: 90%		

★Product specifications are subject to change without notice; please contact us for the latest information.

■ DISTRIBUTED BY

