



1080P

Waterproof Vehicle IR Camera



NEW 2017 JUN. V1.0



AVM-S252C

- 1/2.9" SONY CMOS Sensor
- 2.9mm Lens
- Use 6 units IR LED, Night vision view improved for safety driving.
- Suitable for trucks and buses monitoring
- Waterproof IP66, suitable to install at any places
- Video adjustable for mirroring if in need (Optional)

1080P Waterproof Vehicle IR Camera

AVM-S252C

SPECIFICATIONS

Model No.	AVM-S252C
Video System	NTSC \ PAL
Pick Up	1/2.9" SONY CMOS Sensor
Number of Pixel	1928(H)×1088(V)
Effective Pixels	2.0 Mega Pixel
Resolution	1080P
Sync System	Internal
Scanning system	2 : 1 Interlace
Sensitivity	0.1 LUX
S/N Ratio	Max 50dB
Auto Gain Control	Auto
Mirroring	Optional(BV)
White Balance	Auto
Electronical Shutter	Auto: 1/30NTSC(1/25 PAL)S TO 1/50,000S
Video Output	1 Vp-p Composite Video Output, 75 Ohms
Power Supply	DC 12.0V
Power Consumption	80 mA (IR OFF) / 150mA (IR ON)
Lens	2.9mm
View Angle	H: 90° V:80°
Operating Temperature	- 10° C ~ + 60°C
Dimensions (H x W x D)	57.6 × 52.4. × 55.5 mm
LEDs	6PCS
IR Range	3M
IR Wavelength	850 nm
Waterproof	IP66

★Version updating is not going to inform, please check the on-going updating information

Unit:mm

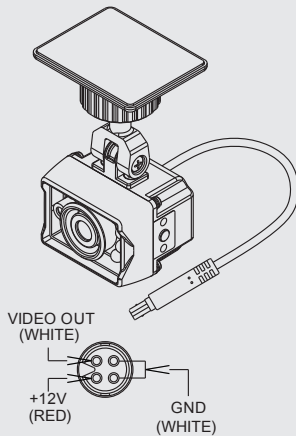
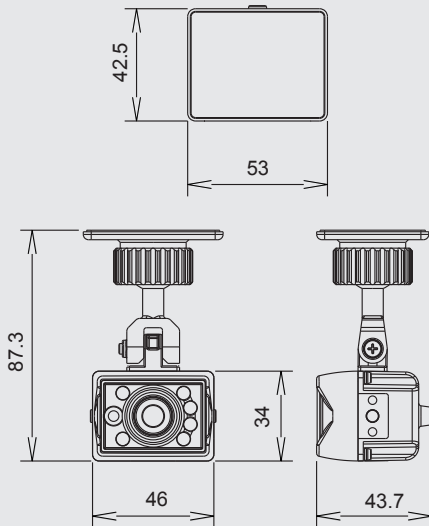

Vehicle Camera Installed instructions

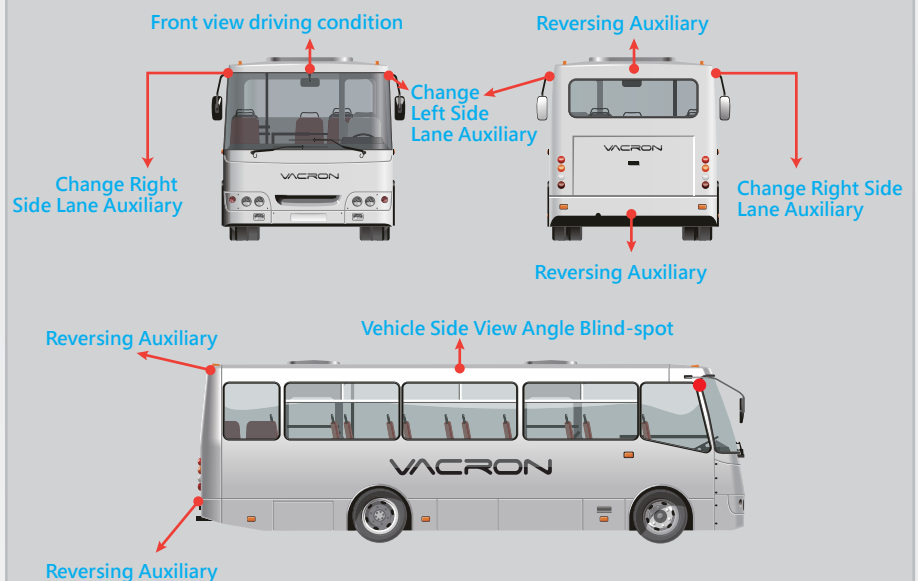

Pictures only for reference, please follow the car condition to install suitable position